

1 | 2 | 3 | 4 | 5

A

B

C

D

E

A

B

C

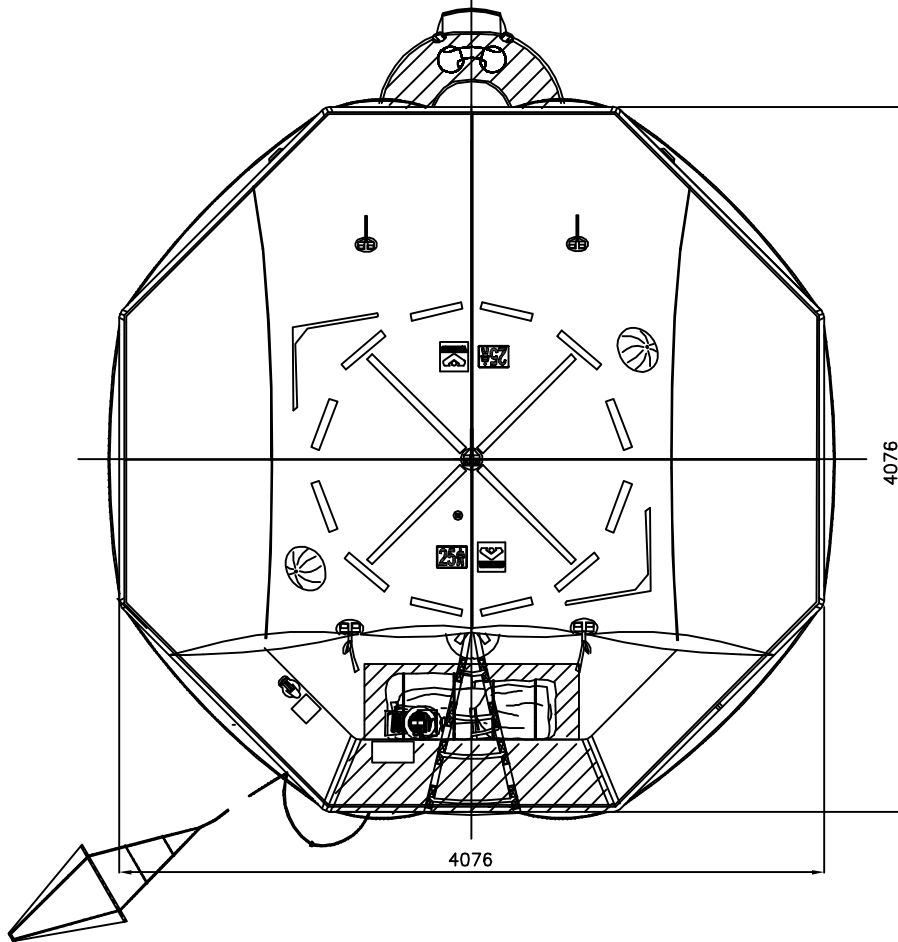
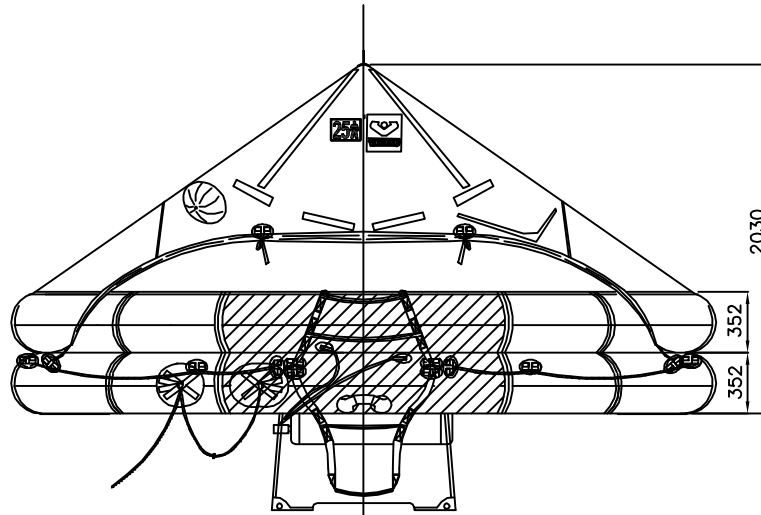

D

E



TOLL. + 2%

Description of change

POS:		Qty.	Description		Material No:	
<p>If the product is requested to be manufactured differently, this MUST be approved by VIKING LIFE-SAVING EQUIPMENT A/S and a specification of change must be filled in if the alteration is approved. Unless otherwise specified the product must always be clearly labelled with Viking part no., manufacturer ID and manufacturing year.</p>						
REVISION NO:	REVISION DESCRIPTION:			REVISION DATE:	APPROVAL INITIALS:	
00	-			-	-	
MATERIAL NO:	STATUS:		UNITS:	CHECK DATE/INITIALS:		
1058504	-		mm	-		
BASIC MATERIAL:	SURFACE TREATMENT:		SHEETSIZE:	SCALE:	SHEET NO:	DRAWN DATE/INITIALS:
-	NA		A3	1:30	01	03.10.2018/CLO
 VIKING LIFE-SAVING EQUIPMENT A/S Sedding Ringvej 13, DK-8710 Eabjerg V Tel.: +45 7811 8100 Fax.: +45 7811 8101 E-mail: viking@viking-life.com Web: www.VIKING-life.com			PROJECTION TYPE:  FIRST ANGLE PROJECTION GENERAL TOLERANCE: + 2%		DESCRIPTION: VIKING LIFE RAFT TYPE 25 DK+ TR2	
Copyright of VIKING LIFE-SAVING EQUIPMENT DENMARK whose property this document remains. No part thereof may be disclosed, copied, duplicated or in any other way made use of except with the approval of VIKING LIFE-SAVING EQUIPMENT DENMARK.						DRAWING NO.:
						-

1 | 2 | 3 | 4 | 5

F