

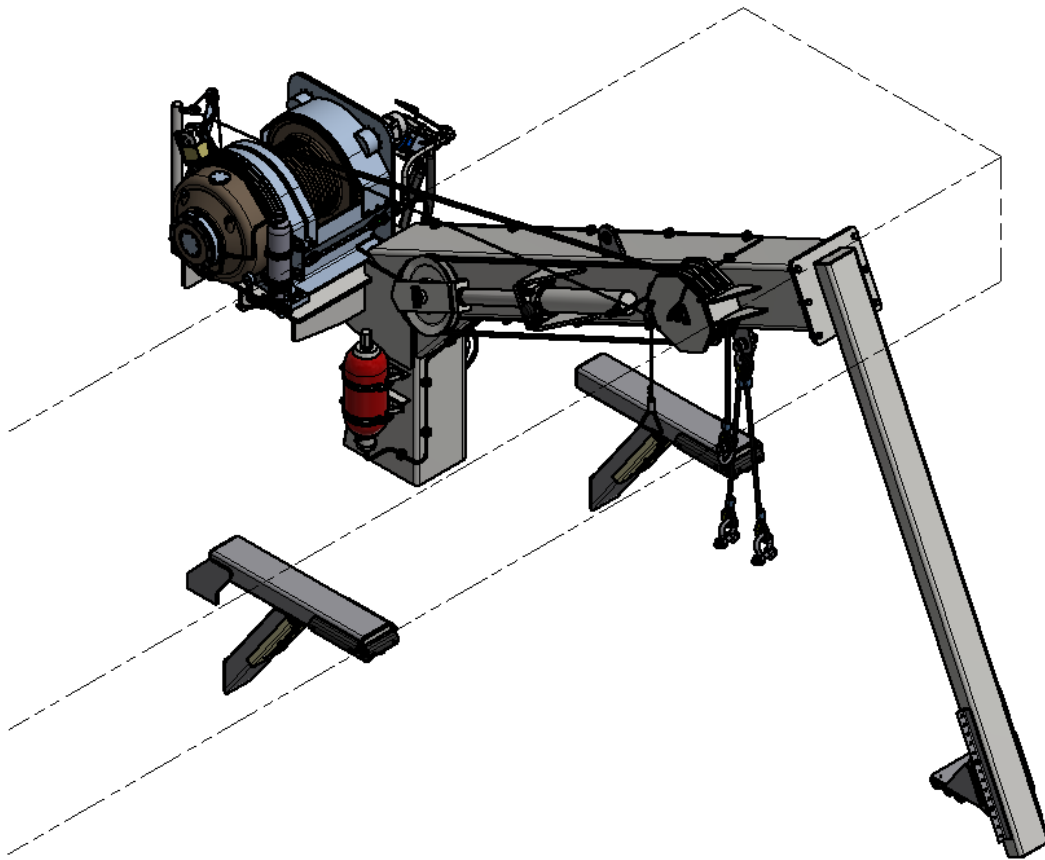

**VIKING
NORSAFE**
Boats and davits

Enterprise No.: NO940411696
www.VIKING-life.com

NDC-65 – Rescue Boat Davit



TECHNICAL SPECIFICATION

VIKING Norsafe Life-Saving Equipment Norway AS
Tybakken 90, N-4818 Faervik
P.O. Box 115, N-4852 Faervik
Arendal, Norway

VIKING Project No.: Standard

VIKING Doc. No.: TSD-0298

Rev. Date: 17.02.2022

Rev. No: 3

Tel: +47 37 05 85 00

Fax: +47 37 05 85 01

E-mail: VIKING-Norsafe@VIKING-life.com

1. REGULATION AND CERTIFICATION

Applicable rules and regulations In accordance with IMO/ SOLAS requirements, LSA Code and European Council Directive 2014/90/EU on Marine Equipment (MED)

| | |
|--------------------------|---|
| Certificate | MED |
| Other certificate | Class certificate or flag acceptance on request |

2. DAVIT SPECIFICATION

2.1. GENERAL DAVIT

| | |
|--|--|
| Type | Cantilever Rescue boat davit |
| Model | NDC-65 |
| Application | Rescue boat handling |
| Drawing reference | G-501794 |
| Execution | Fixed cantilever davit |
| Boarding position | On deck level |
| Operating position | From deck side and from inside the boat (Gravity lowering) |
| Davit system weight (Approx.) | 2550 kg, davit incl. winch (dry weight) |
| Safe Working Load (SWL) | 6625 kg |
| Trim / list conditions | 10° / 20°, 17°/17° |
| Max. lowering height | 62,1 m |
| Operation temperature | -20°C till +45°C (other range on request) |
| Min. hoisting speed | 18 m/min |
| Min. lowering speed | According to SOLAS regulation ($S = 0.4 + 0.02H$) |
| Manual hoisting | By manual hand-cranking |
| Wire sheaves | Galvanized, equipped with ball bearings |
| Installation | 1 (one) deck welding point |
| Deck reinforcement requirements | See general arrangement drawing |
| Davit system H / W / D | See general arrangement drawing |
| Deck space required | See general arrangement drawing |

The Viking Norsafe NDC cantilever davit system is especially designed for safe and efficient launching and retrieval of Viking Norsafe Rescue Boats. The davit system is designed for long time operation in a tough and corrosive marine/offshore environment and to fulfil all requirements as given in latest SOLAS/IMO requirements.

The system will allow:

- Hoisting and lowering of the fully loaded rescue boat up to 20° list and 10° trim.
- Gravity lowering of the fully loaded boat up to 20° list and 10° trim, completely independent of any power supply.

The davit system consist of a cantilever davit arm and a hydraulic driven winch. The winch is controlled from a hydraulic power unit (HPU).



VIKING Project No.: Standard

VIKING Doc. No.: TSD-0298

Rev. Date: 17.02.2022

Rev. No: 3

The davit is designed to achieve optimum performance in terms of safety and reliability, and minimal maintenance levels. All selected equipment is chosen and installed to ensure the lowest possible emission of sound and for good access for service and repair.

A HPU is included, and must be located close to the davit. Hydraulic hoses are connected directly from HPU to davit. A separate control stand with a hydraulic joystick and remote control for start/stop of el motor on HPU is also included. The joystick is controlling two valves inside HPU by hydraulic remote hoses. The control stand has to be installed on deck in a suitable location where good visibility over the davit and boat is obtained.

A safety valve is installed in the hydraulic power unit. This safety valve prevents the davit from lifting loads in excess of the Safe Working Load, and protects the system and motor from being overloaded. The winch is fitted with hydraulically operated, fail-safe multi-disc brake, which is fully oil submerged. In the event of hydraulic pressure loss, due to hose or connection failure, the brake will automatically activate and davit motion will stop.

For launching in dead ship conditions, gravity lowering system in winch provides safe launching. All internal hydraulic piping is properly done and completed on the entire davit system. The only installation work of piping required is the connection of the delivered hydraulic hoses between the hydraulic power unit and the davit.

Starter cabinet is mounted on HPU as standard. All electrical cables for davit control, included 42V AC to rescue boat is installed and terminated by Viking Norsafe. Only main power supply is required.

2.2 WINCH AND WIRE

| | |
|--|--|
| Type | Zollern Hydraulic Winch ZR 4.24 |
| Drawing reference | DS-02377 |
| Execution | Hydraulically hoisting and lowering / Gravity lowering / Manually hoisting |
| Brakes type | Negative multi-disk brakes, hydraulically operated |
| Wire rope type | Galvanized, non-rotating (certified item) |
| Wire rope diameter, MBL and spec. | Ø 20 mm, MBL 382kN, 1960N/mm ² |
| Inner / outer wire end | Secured to drum / Thimble and lifting ring |
| Connection shackle in thimble | Included (certified item) |

2.3. ELECTRICAL

| | |
|------------------------------|--|
| Electric power supply | 440V/3ph/60Hz (other on request) |
| Electrical cabinet | IP56 |
| Remote control | IP56 |
| Limit switch | IP56 |
| Power consumption | 42 kW |
| Starting method | DOL - Direct on line |
| Duty rating | S6-40% |
| Motor space heating | Included, 40W |
| Wiring | Included, (only power supply cable required) |
| Cables type | Marine type, flame retardant halogen free |



| | |
|-----------------------|--|
| Transformer | Included, 440/42VAC (other on request) |
| Emergency stop | Yes, mushroom type |

2.4. HYDRAULIC

| | |
|-----------------------------------|--|
| Type | Independent integrated hydraulic system |
| Oil flow | 74 l/min (at 50Hz); 89 l/min (at 60Hz) |
| Max. working pressure | 240 bar |
| Oil amount | 150 L |
| Motor type | 200L-4 |
| Hydraulic cylinder | DS-00462 |
| Hydraulic accumulator | 1x Bladder type 10L |
| System fittings | ISO 8434-1 (DIN 2353) bite type metric fittings |
| Fittings and hose fittings | Zinc chromate Cr(VI)-free, secured with Denso tape |
| Tubes | AISI 316L |

2.5. PAINTING SYSTEM

| | |
|--|--|
| Blasting | SA 2.5 |
| Specification | ISO 12944-5 |
| System | Marine paint system (Jotun paint system) |
| Coating Two (2) layers (other on request) | Layer 1 Penguard universal, Alu - 190 µm Layer 2 Hardtop XP - 50 µm RAL 9016 (Traffic white) |
| Total dry film thickness | 240 µm |

2.6. DOCUMENTATION

| | |
|---|--|
| Technical specification davit | According to contract specification |
| General arrangement drawing | According to contract specification |
| Electrical wiring diagram | According to contract specification |
| Starter cabinet drawing | According to contract specification |
| Product certificate | According to contract specification |
| Lubrication oil chart | Viking Norsafe standard |
| Spareparts list | Viking Norsafe standard |
| Operation & Maintenance manual | Viking Norsafe standard |
| Installation manual | Viking Norsafe standard |
| Preservation & storage procedure | Viking Norsafe standard |

3. PACKING

| | |
|---------------|---|
| Format | Packed for transport in a 40 ft standard container |
|---------------|---|

4. OPTIONS



VIKING Project No.: Standard

VIKING Doc. No.: TSD-0298

Rev. Date: 17.02.2022

Rev. No: 3

Note: Some options influence davit weight and performance, some option combinations may be incompatible. Maximum SWL must not be exceeded.

marking means to be supplied by maker, marking means not supplied by maker.

| GENERAL DAVIT | |
|--|--------------------------|
| High speed version (Max. hoisting speed: 48m/min) | <input type="checkbox"/> |
| Winterization / cold climate heating / canvas solutions | <input type="checkbox"/> |
| Commissioning performed by Viking Norsafe or Viking Norsafe Service Partners | <input type="checkbox"/> |
| Other options on request | <input type="checkbox"/> |
| ELECTRIC SYSTEM | |
| Voltage variation | <input type="checkbox"/> |
| Protection box for remote control | <input type="checkbox"/> |
| Ex-proof, Zone II 2 G Ex de IIB T3 (other on request) | <input type="checkbox"/> |
| Star Δ starting method | <input type="checkbox"/> |
| Additional electric cabinet heater | <input type="checkbox"/> |
| Alternative cabinet size / material / surface protection | <input type="checkbox"/> |
| HYDRAULIC SYSTEM | |
| Stainless steel fittings and hose fittings | <input type="checkbox"/> |
| Alternative HPU size / material / surface protection | <input type="checkbox"/> |
| HPU heater | <input type="checkbox"/> |
| PAINTING SPECIFICATION | |
| Norsok M-501 system (Viking Norsafe Doc. No. TSS-0030) | <input type="checkbox"/> |
| Other painting system and final color | <input type="checkbox"/> |
| SPARE PARTS | |
| Spare parts for Startup / Commissioning | <input type="checkbox"/> |
| Spare parts for Onboard spare | <input type="checkbox"/> |
| Spare parts for 1 year | <input type="checkbox"/> |
| Spare parts for 2 years | <input type="checkbox"/> |
| DOCUMENTATION | |
| Factory acceptance test procedure | <input type="checkbox"/> |
| Factory acceptance test report | <input type="checkbox"/> |
| Inspection and test plan | <input type="checkbox"/> |
| Shipping, handling and lifting procedure | <input type="checkbox"/> |
| Packing & unpacking procedure | <input type="checkbox"/> |
| Commissioning procedure | <input type="checkbox"/> |
| TAG list | <input type="checkbox"/> |



VIKING Project No.: Standard

VIKING Doc. No.: TSD-0298

Rev. Date: 17.02.2022

Rev. No: 3

| | |
|---|--------------------------|
| Hydraulic flushing procedure | <input type="checkbox"/> |
| Winch drawing | <input type="checkbox"/> |
| Noise test report | <input type="checkbox"/> |
| Hydraulic flushing report | <input type="checkbox"/> |
| Weight and COG datasheet | <input type="checkbox"/> |
| Weighing report/certificate | <input type="checkbox"/> |
| Other drawings/documentation/procedures | <input type="checkbox"/> |

5. POSSIBLE BOAT FITTING THIS DAVIT SYSTEM

The Viking Norsafe boats fit the NDC-65 davit systems.

| | |
|-----------------|---------------------|
| Magnum-850 MKII | (Others on request) |
|-----------------|---------------------|

6. YARD SUPPLY / RESPONSIBILITY

| Transport | Depending on contract |
|---|-----------------------|
| Deck foundations / reinforcement | |
| Assembly, erection and welding to deck | |
| Wire routing on davit and termination | |
| Hydraulic piping between HPU unit, davit and control stand | |
| All cables to starter cabinet and agreed interface | |
| Hydraulic oil filling | |
| Testing according to regulation after installation onboard | |
| Preservation and maintenance after davit arrived yard and installed | |



VIKING Project No.: Standard

VIKING Doc. No.: TSD-0298

Rev. Date: 17.02.2022

Rev. No: 3